



Tools and installation materials

nora[®] rubber flooring

nora[®]
by Interface[®]



Tools and installation materials

nora[®] rubber flooring

Contents

Installation materials	04
Subfloor preparation	10
Installation	14
Joint-sealing	18
Stair and skirting solutions	20
Work trousers	24



Installation materials

Overview of nora[®] installation materials

Use the appropriate products from the following categories to achieve optimum installation. We will be happy to help with any questions you may have about the products or provide specific assembly recommendations

Primer

nora[®] PRP 101 Special primer for porous subfloor



Levelling compounds

nora[®] L 1000 High-performance self-levelling compound

nora[®] SF 1001 Internal repair mortar

nora[®] fibers Reinforcement fibers for nora[®] L 1000



Adhesives

nora[®] AC 100 Acrylic adhesive

nora[®] ED 120 Fiber-reinforced conductive acrylic adhesive

nora[®] PU 102 2-part polyurethane adhesive



All nora[®] installation materials have been awarded the EMICODE[®] EC1^{PLUS} seal (except nora[®] fibres).

Primer and levelling compounds



nora® PRP 101

PU: 10 kg (canister)

121 525

Special primer for porous subfloors. Primer for cement and calcium sulphate screeds as well as for use as a bond between layers of levelling compound.

Consumption: 80 – 150 g/m²



nora® L 1000

PU: 25 kg (bag)

121 520

High performance self-levelling compound (absorbent, stress-free, pumpable).

For filling and levelling DIN-compliant subfloors.

Consumption: 1.5 kg/m² per mm of thickness



nora® SF 1001

PU: 20 kg (bag)

121 523

Internal repair mortar (very stable).

For filling and levelling new and old screeds and subfloors.

Consumption: 1.5 kg/m² per mm of thickness



nora® fibres

PU: 250 g (pouch)

121 522

Reinforcement fibres for self-levelling compounds (high flexural strength).

For increasing structural strength and reducing the formation of cracks in the case of self-levelling compounds.

Consumption: 1 pouch per 25 kg levelling compound

Adhesives

nora® AC 100

PU: 14 kg (bucket)

121 517

Acrylic adhesive for the installation of nora® rubber floor coverings.

noraplan® coverings (2 – 4 mm): Pajarito notched trowel A5, 220 – 250 g/m²

noracare™ coverings (2 mm): Pajarito notched trowel A2, 280 – 320 g/m²

norament® coverings (3.5 – 4 mm): Pajarito notched trowel A2, 280 – 320 g/m²



nora® PU 102

PU: 8 kg (bucket)

121 519

2-component polyurethane adhesive for gluing predominantly norament coverings.

norament coverings (3.5 – 4 mm): Pajarito notched trowel A5, approx. 250 g/m²

(Exception: norament 926/825, pastille design:

Pajarito notched trowel A2, approx. 280 – 320 g/m²)



nora® ED 120

PU: 14 kg (bucket)

121 518

Conductive fibre-reinforced acrylic adhesive for gluing dissipative “ed” and conductive “ec” nora® coverings.

noraplan coverings (2 – 3 mm): Pajarito notched trowel 779/E/21/7, approx. 300 g/m²

norament coverings (3.5 – 4 mm): Pajarito notched trowel 779/E/21/7, approx. 300 g/m²



Copper tape (self-adhesive)

PU: 1 roll of 33 linear metres

118 156





Dry adhesives

Dry adhesives

nora dryfix™

nora dryfix™ 750

PU: 1 roll (30 m x 750 mm)

109 654

Roll-type dry adhesive from the roll to permanent surface bonding.

nora dryfix™ ed

PU: 1 roll (30 m x 750 mm)

126 080

Conductive roll-type dry adhesive for laying dissipative "ed" and conductive "ec" nora® coverings.



nora® stepfix 240

PU: 1 roll (50 m x 240 mm)

94053

Special roll-type dry adhesive for quick installation of norament stairtreads, stairwell installations with nora stair nosing T 5044 and nora® stair margin.



nora® profix

nora® profix 50 (50 m x 50 mm)

PU: 4 rolls

96544

For quick installation of skirting S 1023 U.

nora® profix 90 (50 m x 90 mm)

PU: 2 rolls

96545

For quick installation of skirtings S 1024 U and S 3003 as well as for creating skirtings using wall covers (cushioned edges).





Subfloor preparation

Sanding concrete and screed

nora® nTx sanding disc

PU: 1 unit incl. 5 units nTx K3

for Mambo

117 819

for Columbus

117 820

for Orkan

117 821



nora® nTx K2 sanding tool (coarse)

PU: 5 units

For nora® nTx sanding discs.

117 823



nora® nTx K3 sanding tool (fine)

PU: 5 units

For nora® nTx sanding discs.

117 822



Sandpaper, 60 grit (Ø 400 mm)

PU: 1 unit

For precise sanding of concrete and screed and intermediate sanding of levelling compound.

121 389



Sandpaper, 24 grit (Ø 400 mm)

PU: 1 unit

For precise sanding of concrete and screed and intermediate sanding of levelling compound.

111 922



Spreading



Height levelling spatula

PU: 1 unit

111 925



Screed spreader

PU: 1 unit

111 923

Wooden handle

PU: 1 unit

95627



Levelling compound rake

PU: 1 unit

95626

Wooden handle

PU: 1 unit

95627



Serrated blade for levelling compound rake

PU: 1 set

95699

1x Pajarito notched trowel 777/E/R2

1x smooth

Serrated blade for screed spreader

PU: 1 set

111972

1x Pajarito notched trowel 777/E/R2

1x smooth



Spiked roller

PU: 1 unit

95628

Wooden handle

PU: 1 unit

95627

Expansion strips (50 mm x 5 mm)

PU: 1 box with 5 rolls of 20 linear metres

Self-adhesive

112 539



Mixing bucket (30 litres)

PU: 1 unit

111 711



Priming

Short piled roller with handle

PU: 1 unit

For applying primer.

119 355



Bonding agent

nora® nTx 020 bonding agent

1-component primer for improved adhesion.

Large container

PU: 12 kg (canister)

121 528

Small container

PU: 5 kg (canister)

125 824

Consumption: 100 g/m² single application
200 g/m² double application





Installation

Cutting

Seam cutter for knife blades

PU: 1 unit

Suitable for right-handed and left-handed users.

91062



Straight blade for seam cutters

PU: 10 units

113 676



Delphin® installers knife

PU: 1 unit

120 968



Half moon blade for installers knife

PU: 100 units

113 678



Giant hooked blade for installers knife

PU: 10 units

113 677



Steel straight edge

PU: 1 unit, ~ 2.10 m

91107



Cutting stencil

PU: 1 set

For mitre cuts on inner and outer corners when creating skirtings.

95630





Profile cutter

112 462

PU: 1 unit

For precise cutting of inner and outer stair angles as well as stair nosings.



Replacement blade for profile cutters

112 463

PU: 50 units

Gluing

Adhesive spreader (21 cm)

PU: 1 unit

95611



Serrated blade TKB A2

PU: 10 units

113 692

For nora AC 100 (norament, noracare)



Serrated blade TKB A4

PU: 10 units

113 686



Serrated blade TKB A5

PU: 10 units

113 688

For nora AC 100 (noraplan) and nora PU 102



Smooth adhesive spreader

PU: 1 unit

95612



Mixing spindle

PU: 1 unit

91050

For homogeneous mixing of reaction adhesives.



Cork rubbing board

PU: 1 unit

95624



Iron roller (50 kg)

PU: 1 set (iron roller & carrier)

124 232 + 124 233

Specify both item numbers!





Joint-sealing

Joint-sealing

nora® hot welding rod (round, Ø 4 mm)

PU: 1 roll of 100 linear metres

Matches all noraplan and noracare floor covering colours.



nora® joint sealing compound

PU: 300 ml (cartridge, sufficient for 20 – 25 linear metres)

Extensive colour palette, special colours on request.



Joint cutter

PU: 1 unit

116 950

For cutting flooring seams for nora joint sealing compound and nora hot welding rod.



Blade for cutting grooves for joint cutter

PU: 10 units

116 943



Fast-welding nozzle (Ø 5 mm) with narrow air outlet

PU: 1 unit

112 657

For welding noraplan and noracare coverings with nora hot welding rod. Narrow air outlet prevents both streaks of gloss and burns on both sides of the seam.



Liquid wax

PU: 0.5 l (bottle)

109 914

For waxing seam areas when joint-sealing with nora joint sealing compound.



Smoothing spatula

PU: 2-piece set

120 184

For precise smoothing of nora joint sealing compound.



Mozart trimming knife

PU: 1 unit

120 622



Blades for Mozart trimming knife

PU: 5 units

120 621



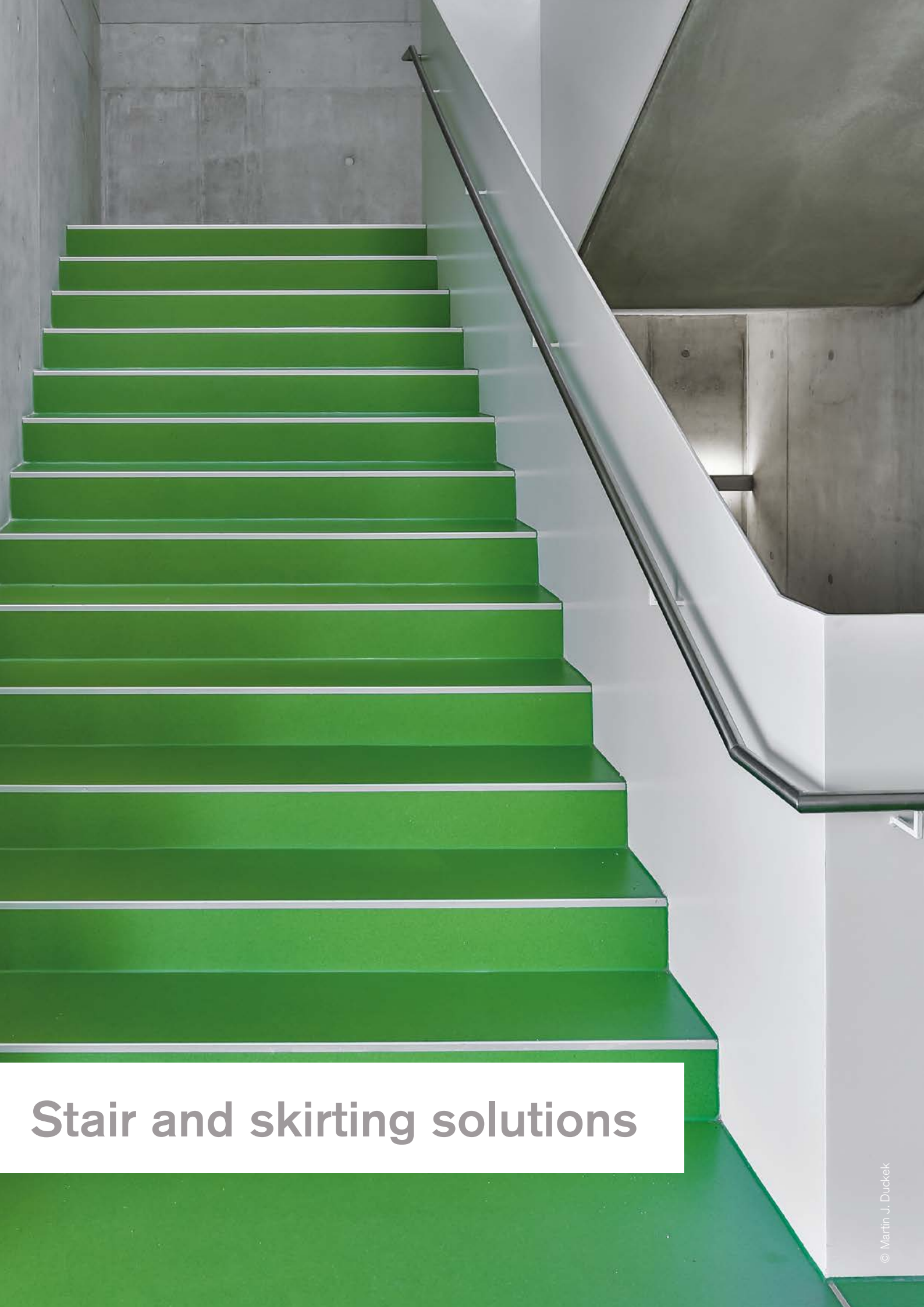

Stair and skirting solutions

Stairs

Repair angle

PU: 30 units incl. 500 screws

127 869



nora® stepfix 240 (50 m x 240 mm)

PU: 1 roll

Special roll-type dry adhesive for quick installation of norament stairtreads, stairwell installations with nora stair nosing T 5044 and nora stair margin.

94053



Stair tool (70 mm)

PU: 1 unit

111 938



Compass (Ø 400 mm)

PU: 1 unit

For transferring unevenness on the wall to floor coverings.

92493



nora® stair nosing T 5044

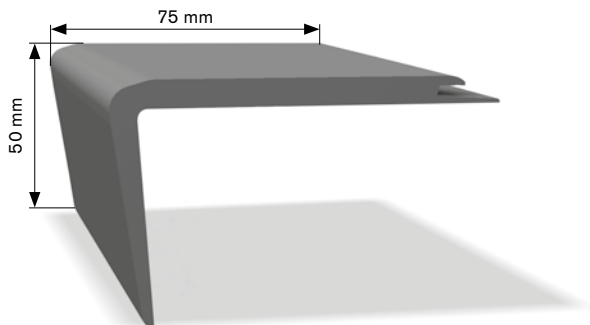

5116	5114	5113
5112	5111	5105

nora® stair nosing T 5049

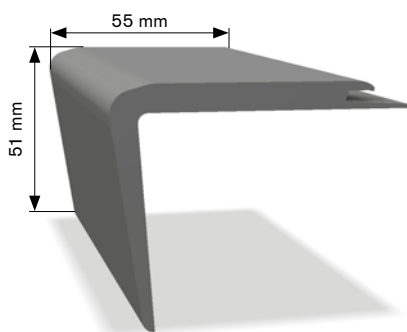

0702	0749	5301	5310
0716	0884	5305	6179

There are two different stair nosings available:
For flooring thicknesses from 2.0 to 2.7 mm (A/C) and from 3.5 bis 4 mm (E/F).
Delivery in 5 fixed lengths possible: 1.00/1.25/1.65/2.0/2.50 linear metres.

nora® stair angles
TW 7006 U (Outer angle)

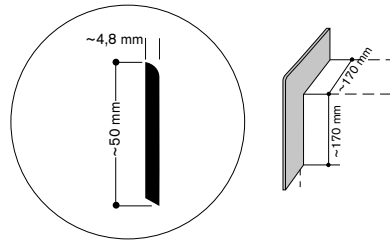

nora® skirting
S 1008 U

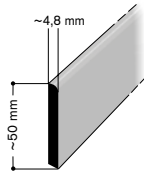

Wall side
 With same cross-section
 as adjoining skirting
 S 1008 U

nora® stair angles
TW 7005 U (Inner angle)

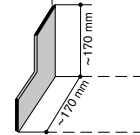

nora® stringer profile
A 5013 U

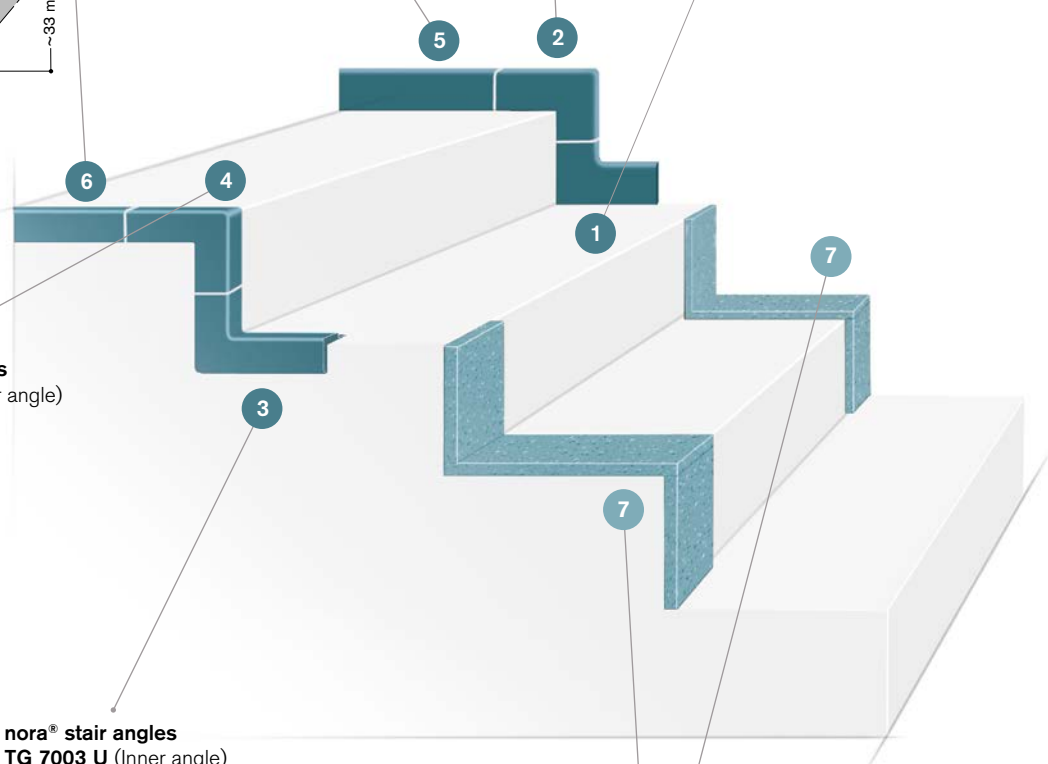
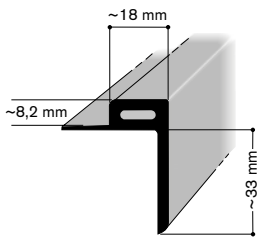

nora® stair angles
TG 7004 U (Outer angle)

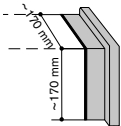

nora® stair angles
TG 7003 U (Inner angle)

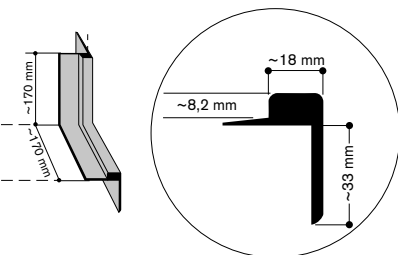

Banister side
 With same cross-section
 as stringer A 5013 U

nora® stair margin

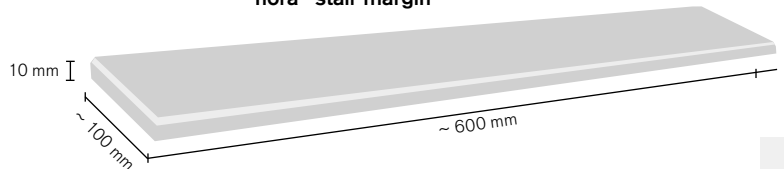

Stairs and skirtings



Rubber mallet

PU: 1 unit

111 937



Superglue

PU: 1 unit, 20 g

121 610

For gluing inner and outer stair angles and for small retrospective gluing jobs.



nora® profix

nora® profix 50 (50 m x 50 mm)

PU: 4 rolls

96544

For quick installation of skirting S 1023 U.



nora® profix 90 (50 m x 90 mm)

PU: 2 rolls

96545

For quick installation of skirtings S 1024 U and S 3003 as well as for creating skirtings using wall covers (cushioned edges).

nora® cushioned-edge profile H 9010

PU: 5 rolls of 10 linear metres

65562

nora® skirtings

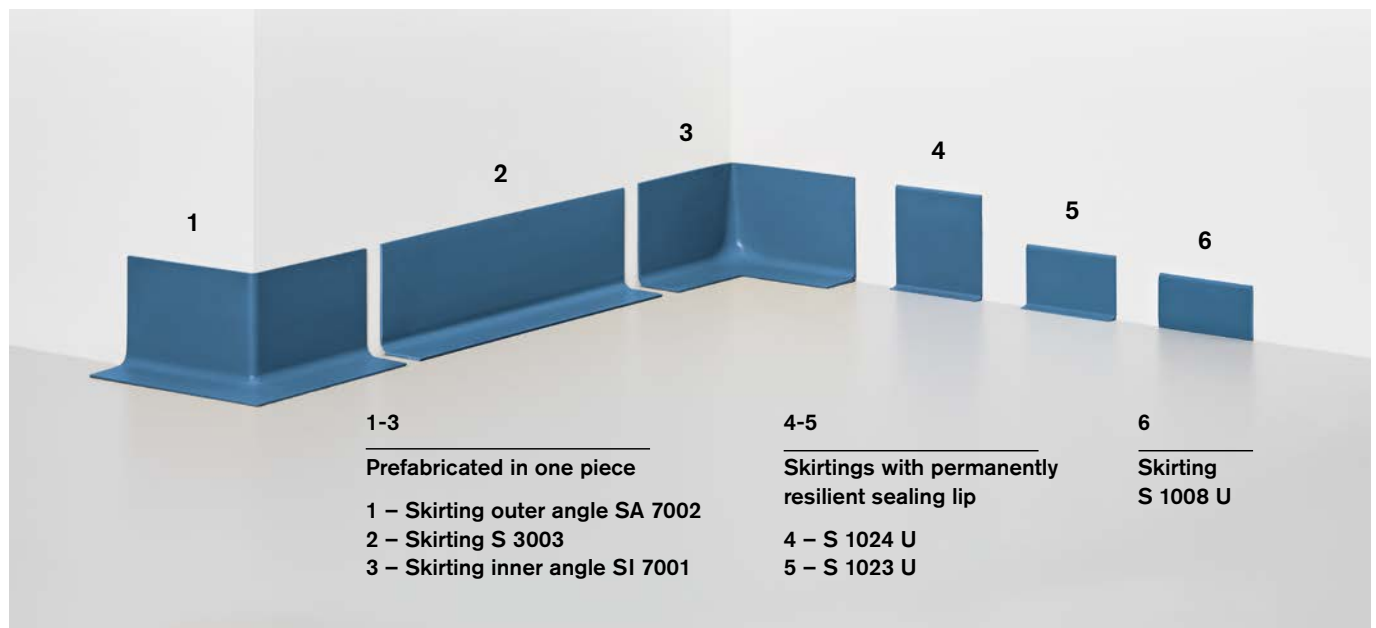

Siteform-coving

Siteform-coving can be carried out with norament, noraplan and noracare floor coverings and is installed with nora profix 90. For an optimum transition from the floor covering to the wall, we offer nora cushioned-edge profile H 9010.





Work trousers

nora® motion work trousers (black)

PU: 1 unit

Size 46	95470
Size 48	93407
Size 50	95471
Size 52	95472
Size 54	95473
Size 56	95474
Size 58	95475
Size 60	99876



Knee pad

PU: 1 set (2 knee pads)

For insertion into work trousers.

95632



Cover photo & product photos: © Elmar Witt

Specifications are subject to change without notice. Errors and omissions excepted.
No liability is assumed for the correctness, completeness or accuracy of the information. The product illustrations in this document may differ from the original.
This document does not constitute a contractual offer and serves only as non-binding information.

The nora brand and any other registered trademarks used in this document are registered to the company, the country or a company affiliated to nora systems GmbH. Any other brand names used herein are the trademarks of their respective owners.

Contact details, local offices, authorized distributors and further information can be found at www.nora.com.

Published by

nora systems GmbH
Höhnerweg 2-4
69469 Weinheim | Germany
www.nora.com